

Your success counts

## Flow computer with temperature and pressure compensation for corrected gas volume



Application examples: Salty Off-Shore conditions



Extreme cold weather at polar regions



Hot and sandy deserts

The F-Series is your first and safest choice for field mount indicators in safe and hazardous area applications. Especially in harsh weather conditions like rain, snow, salty atmospheres and temperatures between  $-40^{\circ}\text{C}$  up to  $+70^{\circ}\text{C}$  ( $-40^{\circ}\text{F}$  up to  $158^{\circ}\text{F}$ ).

### Advantages

- Robust aluminum or stainless steel 316L field enclosure (IP67 / NEMA Type4X). It is so rugged, a truck can even stand on it!
- Intrinsically Safe available - ATEX and IECEx approval for gas and dust applications.
- Programming can be done by your own crew, with the sensible menu-driven structure, saving cost and irritation. Know one, know them all!
- Very diverse mounting possibilities: walls, pipes, panels or directly onto outdoor sensors!

### Features

- Calculates compensated flow rate, total and accumulated total.
- Displays actual line pressure and temperature.
- 11 digit accumulated total.
- 7 digit resettable total.
- Selectable on-screen engineering units; volumetric or mass.
- Ability to process all types of signals: Sine wave (coil), NAMUR, NPN/PNP pulse, Reed-switch, Active pulse signals, 2 or 3 wire PT100 and (0)4 - 20mA inputs.
- Scaled pulse output according to compensated acc. total.
- Analog output according to compensated flow rate.
- Full Modbus communication RS232/485/TTL.
- Power requirements: Loop or battery powered, 8 - 30V DC, 8 - 24V AC/DC or 115 - 230V AC.
- Sensor supply: 3 / 8.2 / 12 / 24V DC.
- Auto backup of settings and running totals.

## Introduction

The flowcomputer Model F126-EG has been developed to calculate the gas volume at normal conditions for generic products, in most cases at 0°C (32 °F) and 1.013 Bar. If desired, any other temperature or pressure can be set. The corrected volumetric flow is calculated using the equations stored in the flowcomputer while a compressibility factor can be set to approach a real gas behaviour.

## Display

The display has large 17mm (0.67") and 8mm (0.31") digits which can be set to show flow rate, total, temperature and pressure. On-screen engineering units are easily configured from a comprehensive menu. The accumulated total can register up to 11 digits and is backed-up in EEPROM memory every minute.

## Configuration

All configuration settings are accessed via a simple operator menu which can be password protected. Each setting is clearly indicated with an alphanumerical description, which avoids confusing abbreviations and baffling codes. Once familiar with one F-series product, you will be able to program all models in the series without a manual. All settings are safely stored in EEPROM memory in the event of sudden power failure.

## Communication

All process data and settings can be read and modified manually or through the Modbus communication link (RS232 / RS485). Full Modbus functionality remains available for the Intrinsically Safe version (TTL).



## Pulse output

The scaleable pulse output, reflects the count on the compensated accumulated display. The pulse width is user defined from 0.001 second up to 9.999 seconds. The maximum output frequency is 500Hz. The output signal can be passive NPN, active PNP or an isolated electro-mechanical relay

## Hazardous areas

This model is ATEX and IECEx certified as Intrinsically Safe for gas applications with an allowed ambient temperature of -40°C to +70°C (-40°F to +158°F) and dust applications with an allowed ambient temperature of -40°C to +50°C (-40°F to +122°F).

## Analog output signal

The calculated flow rate is re-transmitted with the (0)4 - 20mA or 0 - 10V DC output signal. The output signal is updated eight times per second with a filter function being available to smoothen out the signal if desired. The output value is user defined in relation to the flow rate, e.g. 4mA equals to 15Nm<sup>3</sup>/Hr and 20mA equals to 2000Nm<sup>3</sup>/Hr. The output signal can be passive, active or isolated where the passive output type will loop power the F126-EG as well.



All info at a glance



Easy to install



Easy to program



Know one know them all!



Reliable



User-friendly

### Overview application F126-EG

The F-Series is your first and safest choice for field mount indicators in safe and hazardous area applications. Especially in harsh weather conditions like rain, snow, salty atmospheres and temperatures between -40°C up to +70°C (-40°F up to 158°F). Applications where nett gas flow calculation at base conditions is desired. alternative model for explosion proof applications: E126-EG

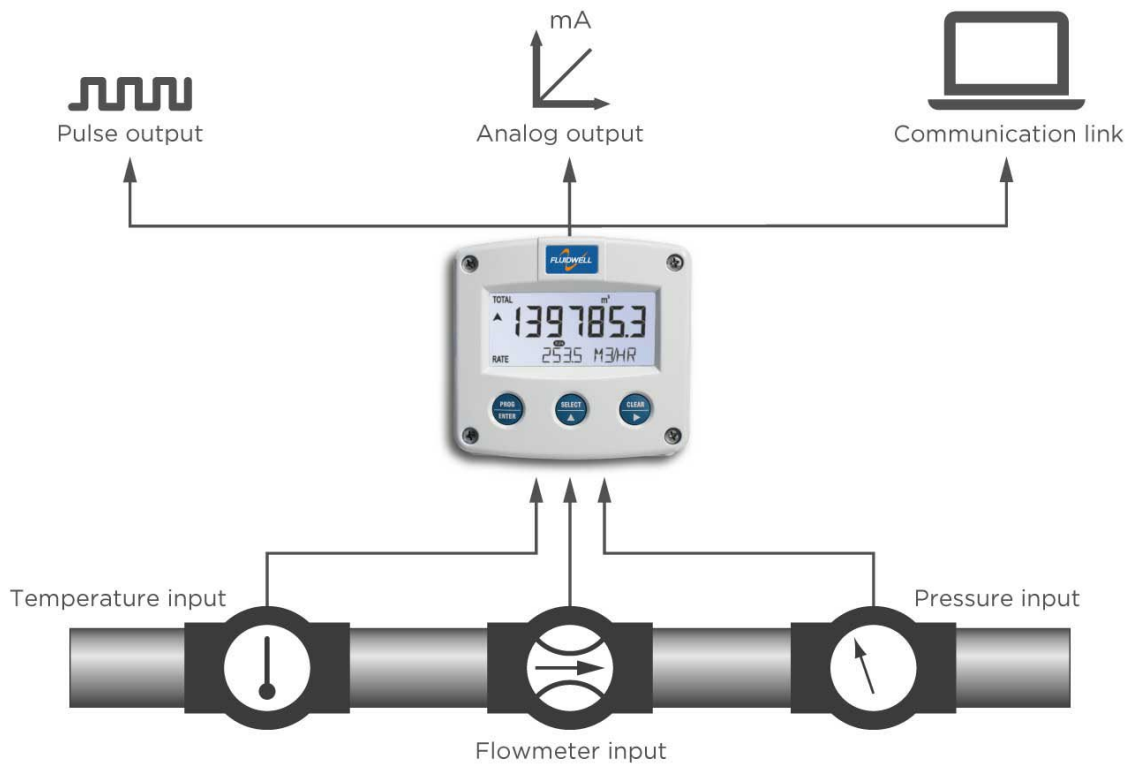

### Signal input

The flowcomputer measures the uncorrected volumetric flow, line temperature and pressure. The F126-EG will accept most pulse input signals for flow. For the temperature measurement, 2 or 3 wire PT100 elements are suitable. For the pressure measurement a (0)4 - 20mA sensor can be used.

Type of signal	Resistance	Low Pass filter (LP)	Max. frequency	Max. frequency Low Pass filter (LP)	Min. amplitude P-P	Remark
NPN	100kΩ pull-up	100kΩ pull-up	6kHz Threshold 1.2V	1.2kHz		Open collector
REED	1MΩ pull-up	1MΩ pull-up	1.2kHz Threshold 1.2V	120Hz		
PNP	100KΩ pull-down	100KΩ pull-down	6kHz Threshold 1.2V	1.2kHz		
NAMUR	820Ω pull-down	-	4kHz	-		External power required
COIL LO	-	-			80mV <sub>pp</sub>	Default sensitivity
COIL-HI					20mV <sub>pp</sub>	Sensitive for interference!
COIL-HI (Type ZF)					10mV <sub>pp</sub>	
ACTIVE 8.2V DC	3K9Ω		10kHz Threshold 4V			External power required
ACTIVE 12V DC	4KΩ		10kHz Threshold 6V			External power required
ACTIVE 24V DC	3KΩ		10kHz Threshold 12V			External power required

## Enclosures

Various types of enclosures can be selected, all ATEX and IECEx approved. The F126-EG is supplied in an GRP panel mount enclosure as standard, which can be converted to an IP67 / NEMA Type4X GRP field mount enclosure by the addition of a back case. Most popular is our robust aluminum field mount enclosure which is also available with an extended backcover with undrilled preparation for direct meter mounting at the back side. It is so rugged, even a truck can stand on it! For the most challenging environments we have a durable high grade Stainless steel 316L enclosure. All enclosures have a IP67 / NEMA Type4X rating and EU or U.S. cable gland entry threads available.

## Dimensions enclosures

Aluminum & GRP panel mount enclosure

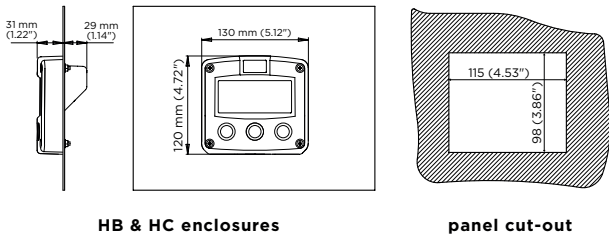

HB & HC enclosures

panel cut-out

Cable entries

### Aluminum / Stainless Steel

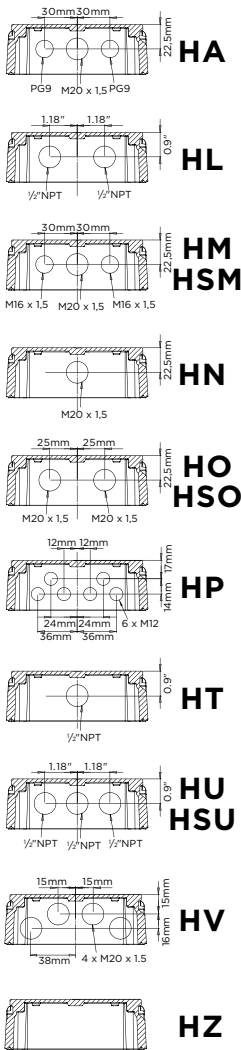

### GRP

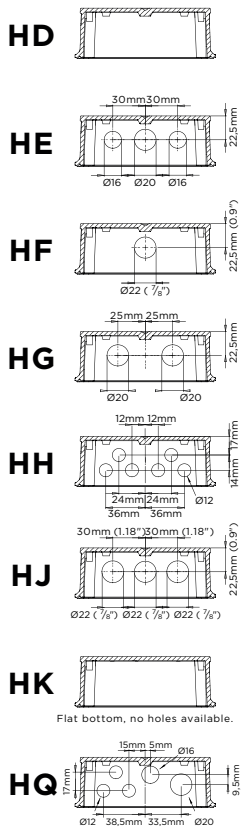

### Extended Aluminum

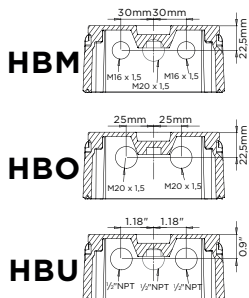

Aluminum, GRP & Stainless steel 316L field mount enclosures

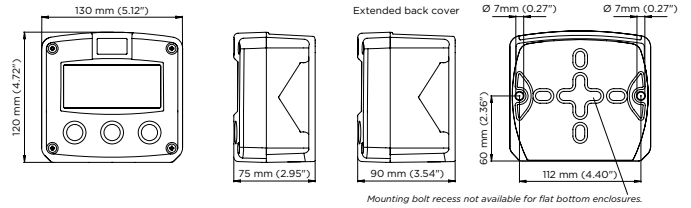

Mounting bolt recess not available for flat bottom enclosures.

## Terminal connections

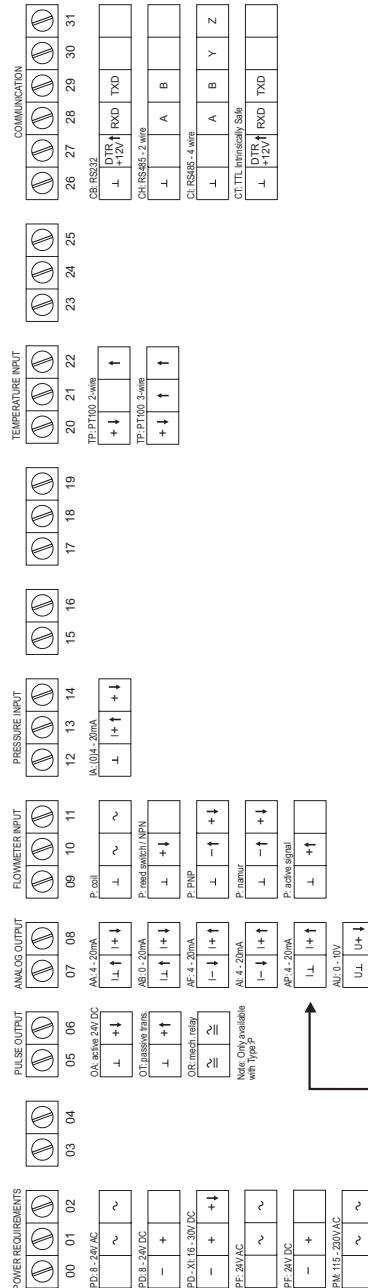

PG: PC battery powered internal long life lithium battery

Configuration example F126-P-AP-CH-EG-IA-OT-(PX)-TP-XX-ZX

Configuration example F126-P-AI-CI-EG-IA-OR-TP-XX-ZX

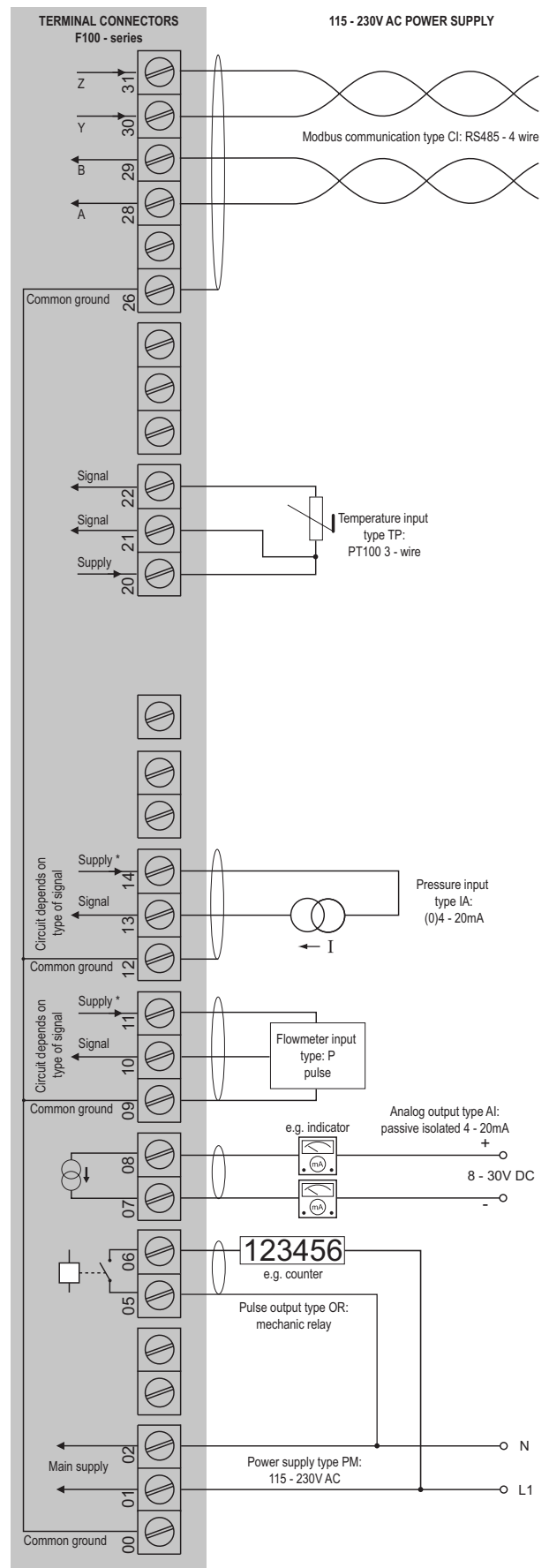
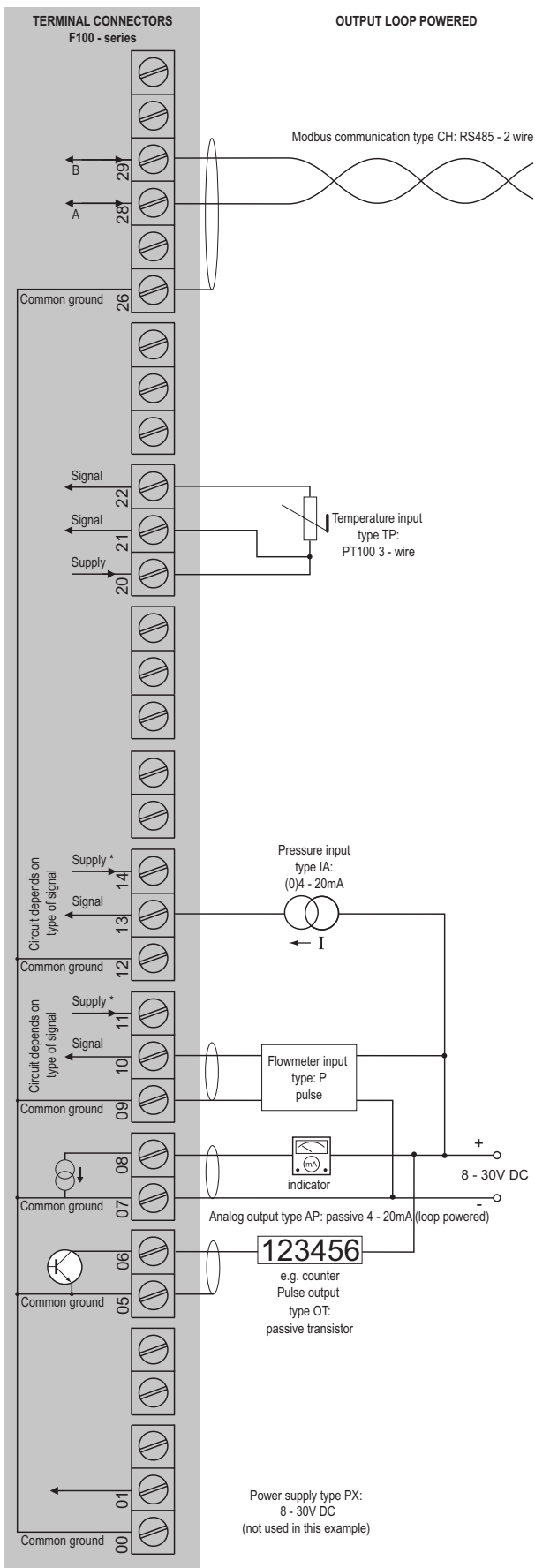

\* For pulse type inputs:  $V_{ref}$ : 1.2V/3.0V available.- NO power output, available  $I_{supply}$ : <1mA. Note: using these ref. voltages at max. load, will reduce battery life significantly.

\*Supply voltage: 3.2 / 8.2 / 12 / 24V DC to sensor

## Hazardous area applications

The F126-EG-XI has been certified according to ATEX and IECEx by DEKRA for use in Intrinsically Safe applications with an ambient temperature of -40°C to +70°C (-40°F to +158°F). For equipment category Dust, zone 20 (1 D / EPL Da), the maximum ambient temperature is limited to 50°C (+122°F) and a maximum dust layer thickness of 200mm.

- The ATEX markings for gas and dust applications are:

Gas: **II 1 G Ex ia IIB/IIC T4 Ga.**

Dust: **II 1 D Ex ia IIIC T<sub>200</sub> 100 °C Da.**

- The IECEx markings for gas and dust applications are:

Gas: **Ex ia IIC/IIB T4 Ga.**

Dust: **Ex ia IIIC T<sub>200</sub> 100 °C Da.**

It is allowed to connect up to six barriers in IIB/IIIC applications or one barrier in IIC applications. Consult the certificate for the maximum input and output values of the circuits. Full functionality of the F126-EG remains available, including 4 - 20mA output according to the flow rate and Modbus communication (type CT). Power supply type PD-XI offers a 8.2V sensor supply e.g. for one Namur sensor and two analog sensors. An ATEX approved flame proof Ex d enclosure is available as well. Please contact your supplier for further details.

## Certificate of conformity KEMA 03ATEX1074 X

- IECEX DEK 11.0042X

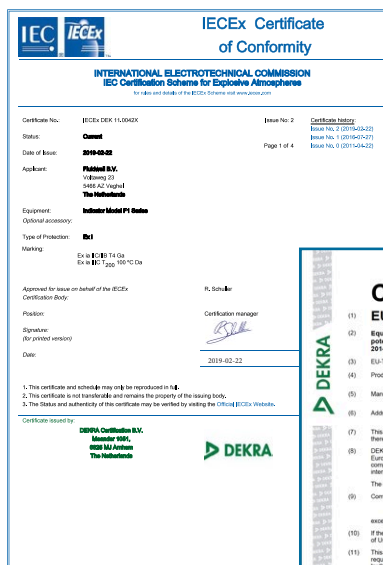

## Configuration example IIB / IIIC and IIC - F126-P-(AP)-(CT)-EG-IA-(OT)-PC-TP-XI - Battery powered unit

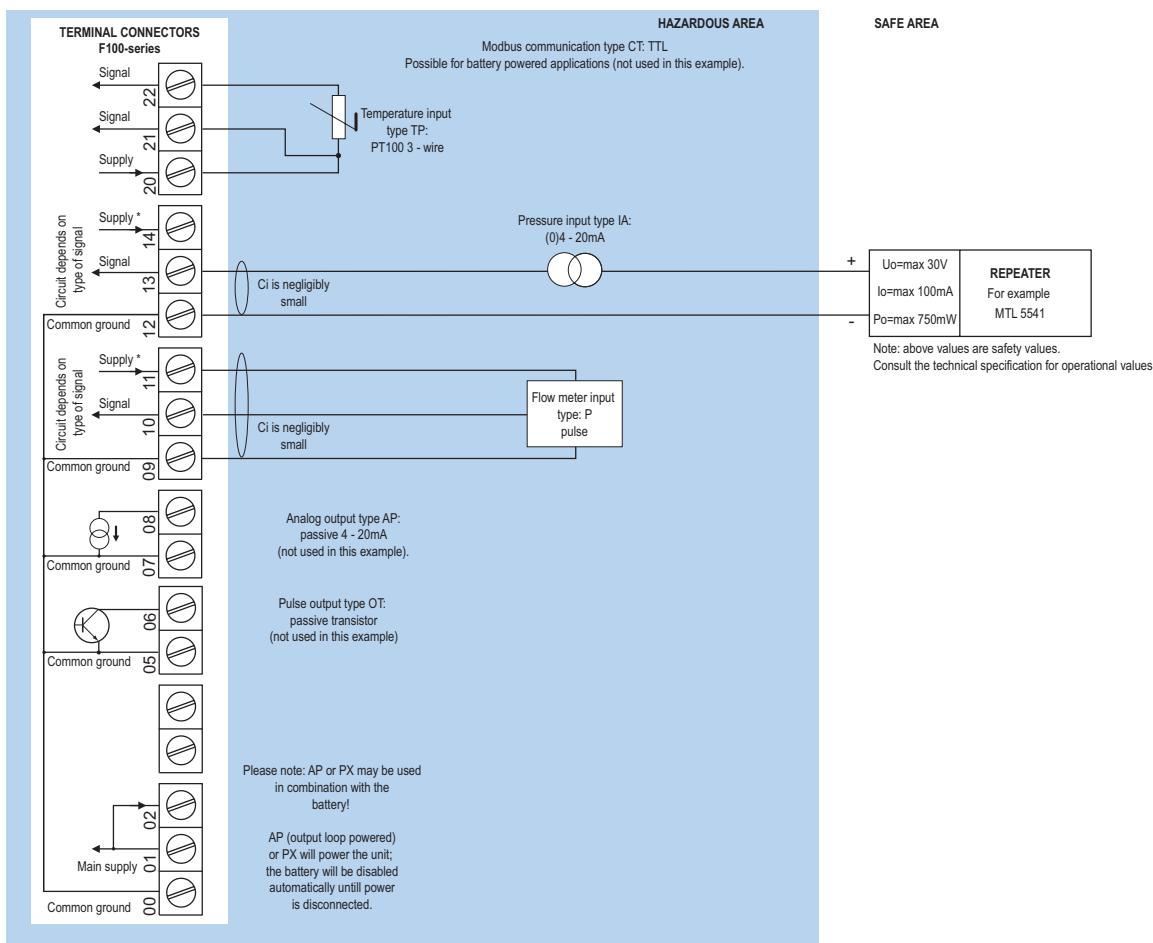

\* For pulse type inputs: V<sub>ref</sub>: 1.2V/3.0V available - NO power output, available I<sub>ref</sub>: <1mA.  
Note: using these ref. voltages at max. load, will reduce battery life significantly.  
Note IIC applications: Only one power supply is allowed in IIC applications.

## Configuration example IIB / IIIC - F126-P-AP-CT-EG-IA-OT-(PX)-TP-XI - Output loop powered

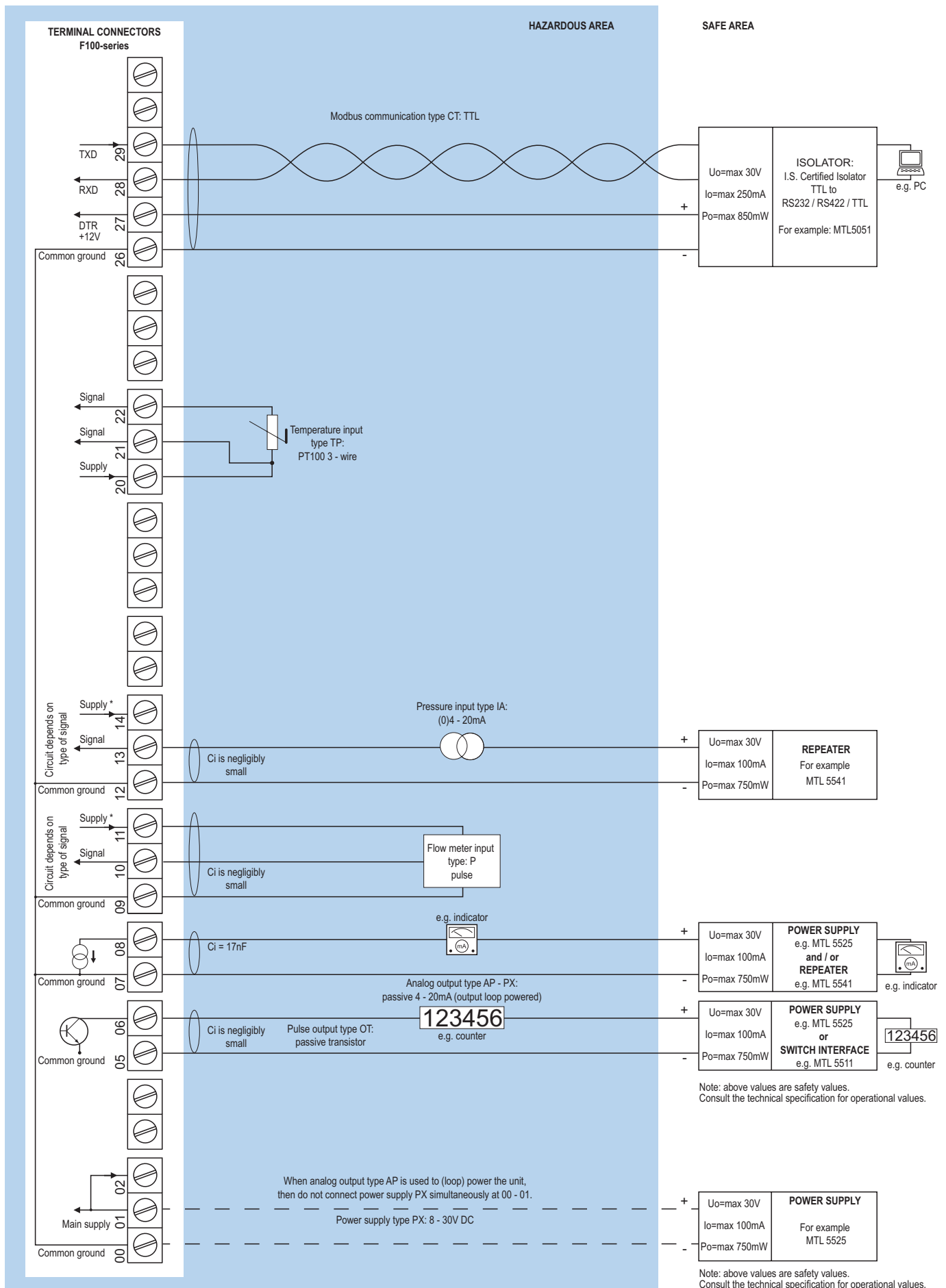

\* For pulse type inputs:  $V_{ref}$ : 1.2V/3.0V available.- NO power output, available  $I_{supply}$ : <1mA.  
 Note: using these ref. voltages at max. load, will reduce battery life significantly.  
 Note IIC applications: Only one power supply is allowed in IIC applications.

Configuration example IIB / IIIC - F126-P-AF-CT-EG-IA-OT-(PC)-(PD)-TP-XI - Power requirement 16 - 30V DC or battery powered

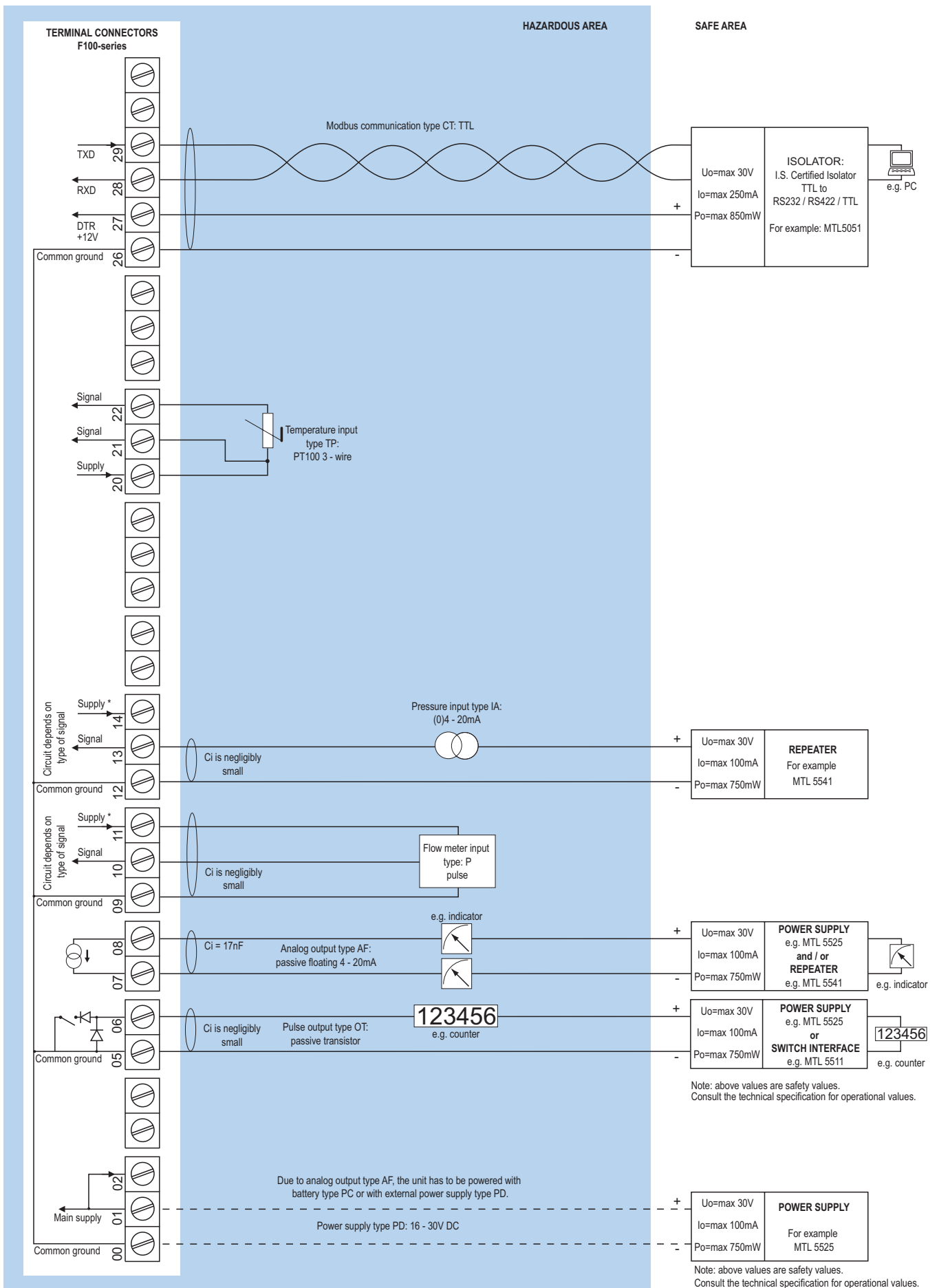

## Display

<b>Type</b>	High intensity reflective numeric and alphanumeric LCD, UV-resistant.
<b>Dimensions</b>	90 x 40mm (3.5" x 1.6").
<b>Digits</b>	Seven 17mm (0.67") and eleven 8mm (0.31") digits. Various symbols and measuring units.
<b>Refresh rate</b>	User definable: fast, 1sec, 3sec, 15sec, 30sec, off.
<b>Option ZB</b>	Transflective LCD with white LED-backlight. Intensity can be adjusted in the configuration menu. Good readings in full sunlight and darkness.
<b>Note ZB</b>	Only available for safe area applications.

## Ambient temperature

<b>Safe areas</b>	-40°C to +70°C (-40°F to +158°F).
<b>Intrinsically Safe</b>	-40°C to +70°C (-40°F to +158°F).
<b>Dust, zone 20</b>	-40°C to +50°C (-40°F to +122°F).

## Terminal connections

<b>Type</b>	Removable plug-in terminal strip. Wire max. 1.5mm <sup>2</sup> and 2.5mm <sup>2</sup> .
-------------	---

## Data protection

<b>Type</b>	EEPROM backup of all settings. Backup of running totals every minute. Data retention at least 10 years.
<b>Password</b>	Configuration settings can be password protected.

## Directives & Standards

<b>EMC</b>	EN 61326-1, FCC 47 CFR part 15.
<b>Low voltage</b>	EN/IEC 61010-1, CSA C22.2 No.61010-1, UL61010-1
<b>ATEX (Type XI)</b>	EN IEC 600079-0, EN 60079-11.
<b>IECEX (Type XI)</b>	IEC 600079-0, IEC 60079-11.
<b>RoHS</b>	EN 50581, IEC 63000
<b>IP &amp; NEMA</b>	EN 60529, ANSI/IEC 60529, NEMA 250

## Intrinsically Safe (Type XI)

<b>ATEX</b>	Gas: II 1 G Ex ia IIB/IIC T4 Ga. Dust: II 1 D Ex ia IIIC T <sub>200</sub> 100 °C Da.
<b>IECEX</b>	Gas: Ex ia IIC/IIB T4 Ga. Dust: Ex ia IIIC T <sub>200</sub> 100 °C Da.
<b>Ambient Ta</b>	-40°C to +70°C (-40°F to +158°F).
<b>Dust, zone 20</b>	-40°C to +50°C (-40°F to +122°F).

## Enclosure

<b>Window</b>	Polycarbonate window.
<b>Sealing</b>	Silicone.
<b>Control keys</b>	Three industrial micro-switch keys. UV-resistant silicone keypad.

## Panel mount enclosures

<b>Dimensions</b>	130 x 120 x 60mm (5.12" x 4.72" x 2.36") - W x H x D.
<b>Panel cut-out</b>	115 x 98mm (4.53" x 3.86") L x H.
<b>Type HB</b>	Die-cast aluminum panel mount enclosure IP65 / NEMA Type4X.
<b>Weight</b>	600 gr.
<b>Type HC</b>	GRP panel mount enclosure IP65 / NEMA Type4X, UV-resistant and flame retardant.
<b>Weight</b>	450 gr.
<b>Type HSB</b>	Die-cast stainless steel 316L IP67 / NEMA Type4X.
<b>Weight</b>	1150gr.

## GRP wall / field mount enclosures

<b>General</b>	GRP wall/field mount enclosure IP67 / NEMA Type4X, UV-resistant and flame retardant.
<b>Dimensions</b>	130 x 120 x 75mm (5.12" x 4.72" x 2.95") - W x H x D.
<b>Weight</b>	600 gr.
<b>Type HD</b>	Cable entry: no holes.
<b>Type HE</b>	Cable entry: 2 x Ø 16mm and 1 x Ø 20mm.
<b>Type HF</b>	Cable entry: 1 x Ø 22mm (7/8").
<b>Type HG</b>	Cable entry: 2 x Ø 20mm.
<b>Type HH</b>	Cable entry: 6 x Ø 12mm.
<b>Type HJ</b>	Cable entry: 3 x Ø 22mm (7/8").
<b>Type HK</b>	Flat bottom, cable entry: no holes.
<b>Type HQ</b>	Cable entry: 1 x Ø 20mm, 1 x Ø 16mm & 3 x Ø 12mm.

## Aluminum wall / field mount enclosures

<b>General</b>	Die-cast aluminum wall/field mount enclosure IP67 / NEMA Type4X with 2-component UV-resistant coating. Extended back cover available with undrilled preparation for direct meter mounting.
<b>Dimensions</b>	130 x 120 x 75mm (5.12" x 4.72" x 2.95") - W x H x D. 130 x 120 x 90mm (5.12" x 4.72" x 3.54") - W x H x D.
<b>Weight</b>	1100 gr. / extended enclosure: 1310 gr.
<b>Type HA</b>	Cable entry: 2 x PG9 and 1 x M20.
<b>Type HL</b>	Cable entry: 2 x 1/2" NPT.
<b>Type HM/HBM</b>	Cable entry: 2 x M16 and 1 x M20.
<b>Type HN</b>	Cable entry: 1 x M20.
<b>Type HO/HBO</b>	Cable entry: 2 x M20.
<b>Type HP</b>	Cable entry: 6 x M12.
<b>Type HT</b>	Cable entry: 1 x 1/2" NPT.
<b>Type HU/HBU</b>	Cable entry: 3 x 1/2" NPT.
<b>Type HV</b>	Cable entry: 4 x M20.
<b>Type HZ</b>	Cable entry: no holes.

## Stainless steel 316L wall / field mount enclosures

<b>General</b>	Die-cast stainless steel 316L wall / field mount enclosure with flat bottom. IP67 / NEMA Type4X.
<b>Dimensions</b>	130 x 120 x 75mm (5.12" x 4.72" x 2.95") - W x H x D.
<b>Weight</b>	2700 gr.
<b>Type HSM</b>	Cable entry: 2 x M16 + 1 x M20.
<b>Type HSO</b>	Cable entry: 2 x M20.
<b>Type HSU</b>	Cable entry: 3 x 1/2" NPT.

## Signal inputs - Flowmeter

<b>Type P</b>	Coil / sine wave (HI: 20mVpp or LO: 80mVpp - sensitivity selectable), NPN/PNP, open collector, reed switch, Namur, active pulse signals 8 - 12 and 24V DC.
<b>Frequency</b>	Minimum 0Hz - maximum 6kHz for total and flow rate. Maximum frequency depends on signal type and internal low-pass filter. E.g. reed switch with low-pass filter: max. frequency 120Hz.
<b>K-Factor</b>	0.000010 - 9,999,999 with variable decimal position.
<b>Low-pass filter</b>	Available for all pulse signals.
<b>Option ZF</b>	coil sensitivity 10mVpp.

## Signal inputs - Temperature

<b>Update time</b>	One time per two seconds.
<b>Type TP</b>	2 or 3 wire PT100.
<b>Range</b>	-100°C to +200°C (-148°F to 392°F). Accuracy 0.1°C (0.18°F).
<b>Option ZV</b>	Range: -200°C to +800°C (-328°F to 1832°F). Accuracy 0.5°C (0.9°F).

## Signal inputs - Pressure

<b>Accuracy</b>	Resolution: 14 bit. Error < 0.025mA / ± 0.125% FS. Low level cut-off programmable.
<b>Update time</b>	Four times per second.
<b>Type IA</b>	(0)4 - 20mA. Analog input signal can be scaled to any desired range within 0 - 20mA.
<b>Span</b>	0.000010 - 9,999,999 with variable decimal position.
<b>Offset</b>	0.000 - 9,999.999.
<b>Voltage drop</b>	2.5V @ 20mA.
<b>Note</b>	For signal type IA: external power to sensor required; e.g. PD.

## Signal outputs - Digital output

<b>Function</b>	Pulse output - transmitting compensated accumulated total.
<b>Frequency</b>	Max. 500Hz. Pulse width user definable between 0.001 second up to 9.999 seconds.
<b>Type OA</b>	One active 24V DC transistor outputs (PNP); max. 50mA per output (requires -PD, PF, PM or PX). Requires min. 24V power supply
<b>Type OR</b>	One electro-mechanical relay output isolated max. switch power 230V AC (N.O.) - 0.5A per relay (requires PF or PM).
<b>Type OT</b>	One passive transistor output (NPN) - not isolated. Max. 50V DC - 300mA per output.

## Signal outputs - Analog output

<b>Function</b>	Transmitting compensated flow rate.
<b>Accuracy</b>	10 bit. Error < 0.05%. Analog output signal can be scaled to any desired range.
<b>Update time</b>	Eight times per second.
<b>Type AA</b>	Active 4 - 20mA output (requires PD, PF, PM or PX).
<b>Type AB</b>	Active 0 - 20mA output (requires PD, PF, PM or PX).
<b>Type AF</b>	Passive floating 4 - 20mA output (requires XI + PD).
<b>Type AI</b>	Passive galvanically isolated 4 - 20mA output - also available for battery powered models.
<b>Type AP</b>	Passive 4 - 20mA output - not isolated. Unit will be loop powered.
<b>Type AU</b>	Active 0 - 10V DC output. Requires min. 12V power supply.

## Signal outputs - Communication option

<b>Function</b>	Reading display information, reading / writing all configuration settings.
<b>Protocol</b>	Modbus ASCII / RTU.
<b>Speed</b>	1200 - 2400 - 4800 - 9600 baud.
<b>Addressing</b>	Maximum 255 addresses.
<b>Type CB</b>	RS232
<b>Type CH</b>	RS485 2-wire
<b>Type CI</b>	RS485 4-wire
<b>Type CT</b>	TTL Intrinsically Safe.

## Power requirements

<b>Type AP</b>	Analog output loop powered, 8 - 30V DC. Power consumption max 0.5 Watt.
<b>Type PB</b>	Long life Lithium battery - life-time depends upon settings and configuration - up to 5 years. (requires PD, PL or PX)
<b>Type PC</b>	Intrinsically Safe long life lithium battery life-time depends upon settings and configuration - up to 5 years. (requires XI and PD, PL or PX)
<b>Type PD</b>	8 - 24V AC / 8 - 30V DC. Power consumption max. 5W.
<b>Type PD-XI</b>	6 - 30V DC; powerconsumption max. 1W.
<b>Type PD-ZB:</b>	10 - 24V AC / 12 - 30V DC; Power consumption max. 5W.
<b>Type PF</b>	15 - 24V AC / 20 - 30V DC. Power consumption max. 15W.
<b>Type PM</b>	115 - 230V AC. Power consumption max. 15W.
<b>Type PX</b>	8 - 30V DC. Power consumption max. 0.75W.
<b>Type PX-ZB:</b>	12 - 30V DC; Power consumption max. 1.5W.
<b>Note PB/PF/PM</b>	Not available Intrinsically Safe.
<b>Note PF/PM</b>	The total consumption of the sensors and outputs may not exceed 400mA @ 24V.
<b>Note XI</b>	For Intrinsically Safe applications, consult the safety values in Annex 1 of the certificate.

## Sensor excitation

<b>Type PB/PC/AP</b>	3V DC for pulse signals and 1.2V DC for coil pick-up - max. 0,1mA.
<b>Type PX</b>	3V DC for pulse signals and 1.2V DC for coil pick-up - max. 1mA.
<b>Note PB/PC/PX/AP</b>	This is not a real sensor supply. Only suitable for sensors with a very low power consumption like coils (sine wave) and reed-switches.
<b>Type PD</b>	1.2 / 3 / 8.2 / 12 / 24V DC - max. 50mA @ 24V DC. $U_{max}$ sensor is 2V below $U_{supply}$
<b>Type PD-XI</b>	1.2 / 3 / 8.2V DC - max. 7mA @ 8.2V DC and mains power supply voltage (as connected to terminal 1).
<b>Type PF</b>	1.2 / 3 / 8.2 / 12 / 24V DC max. 50mA @ 8.2/12/24V DC.
<b>Type PM</b>	1.2 / 3 / 8.2 / 12 / 24V DC max. 50mA @ 8.2/12V DC or 400mA @ 24V DC

## Flow equations

<b>Type EG</b>	Corrected gas volume.
<b>Formula</b>	$Q_{normal} = Q \times \left( \frac{P}{P_{ref}} \right) \times \left( \frac{T_{ref}}{T} \right) \times \left( \frac{C_{ref}}{C} \right)$
<b>Normal press.</b>	Default: 1.013 bar.
<b>Normal temp.</b>	Default: 273.15K (0°C / 32°F)

## Operator functions

<b>Displayed info</b>	<ul style="list-style-type: none"> <li>• Compensated flow rate.</li> <li>• Compensated total and accumulated total.</li> <li>• Actual line temperature / pressure.</li> <li>• Reset total by pressing the CLEAR-key twice.</li> </ul>
-----------------------	---

## Total

<b>Digits</b>	7 digits.
<b>Units</b>	L, m <sup>3</sup> , GAL, USGAL, kg, lb, bbl, no unit.
<b>Decimals</b>	0 - 1 - 2 or 3.
<b>Note</b>	Total can be reset to zero.

## Accumulated total

<b>Digits</b>	11 digits.
<b>Units / decimals</b>	According to selection for total.
<b>Note</b>	Can not be reset to zero.

## Flow rate

<b>Digits</b>	7 digits.
<b>Units</b>	mL, L, m <sup>3</sup> , Gallons, kg, Ton, lb, bl, cf, RND, ft <sup>3</sup> , scf, Nm <sup>3</sup> , NI, igal - no units.
<b>Decimals</b>	0 - 1 - 2 or 3.
<b>Time units</b>	/sec - /min - /hr - /day.

## Line temperature

<b>Digits</b>	6 digits.
<b>Units</b>	°C, °F or K.
<b>Decimals</b>	1.

## Line pressure

<b>Digits</b>	6 digits.
<b>Units</b>	mbar, bar, PSI, no-unit.
<b>Decimals</b>	1.

	Description		
Model	<b>F126-EG</b>	<b>Flowcomputer with temperature and pressure compensation for corrected gas volume.</b>	
Input	<b>P</b>	<b>Pulse input, e.g., coil, npn, pnp, namur.</b>	
Analog output	AA	Active 4 - 20mA output - requires XX.	
	AB	Active 0 - 20mA output - requires XX.	
	AF	I.S. floating 4 - 20mA output - requires XI + PD.	
	AI	Isolated 4 - 20mA output - requires XX.	
	<b>AP</b>	<b>Passive 4 - 20mA output, loop powered unit.</b>	
	AU	Active 0 - 10V DC output - requires XX.	
Communication	CB	Communication RS 232 - Modbus RTU - requires XX.	
	CH	Communication RS 485 - 2wire - Modbus RTU - requires XX.	
	CI	Communication RS 485 - 4wire - Modbus RTU - requires XX.	
	CT	Intrinsically Safe TTL - Modbus RTU - requires XI.	
	<b>CX</b>	<b>No communication.</b>	
Equation	<b>EG</b>	<b>Corrected gas volume.</b>	
Enclosures	HB	Aluminum panel mount enclosure.	
	<b>HC</b>	<b>GRP panel mount enclosure.</b>	
	HSB	Stainless steel 316L panel mount enclosure.	
	HD	GRP field mount - Cable entry: no holes.	
	HE	GRP field mount - Cable entry: 2 x Ø 16mm & 1 x Ø 20mm.	
	HF	GRP field mount - Cable entry: 1 x Ø 22mm ( $\frac{7}{8}$ ").	
	HG	GRP field mount - Cable entry: 2 x Ø 20mm.	
	HH	GRP field mount - Cable entry: 6 x Ø 12mm.	
	HJ	GRP field mount - Cable entry: 3 x Ø 22mm ( $\frac{7}{8}$ ").	
	HK	GRP field mount - Flat bottom, cable entry: no holes.	
	HQ	GRP field mount - Cable entry: 1 x Ø 20mm, 1 x Ø 16mm & 3 x Ø 12mm.	
	HA	Aluminum field mount - Cable entry: 2 x PG9 + 1 x M20.	
	HL	Aluminum field mount - Cable entry: 2 x $\frac{1}{2}$ "NPT.	
	HM	Aluminum field mount - Cable entry: 2 x M16 + 1 x M20.	
	HN	Aluminum field mount - Cable entry: 1 x M20.	
	HO	Aluminum field mount - Cable entry: 2 x M20.	
	HP	Aluminum field mount - Cable entry: 6 x M12.	
	HT	Aluminum field mount - Cable entry: 1 x $\frac{1}{2}$ "NPT.	
	HU	Aluminum field mount - Cable entry: 3 x $\frac{1}{2}$ "NPT.	
	HV	Aluminum field mount - Cable entry: 4 x M20.	
	HZ	Aluminum field mount - Cable entry: no holes.	
	HBM	Extended Alu. field/meter mount - Cable entry: 2 x M16 + 1 x M20.	
	HBO	Extended Alu. field/meter mount - Cable entry: 2 x M20.	
	HBU	Extended Alu. field/meter mount - Cable entry: 3 x $\frac{1}{2}$ "NPT.	
	HSM	Stainless steel 316L field mount - Cable entry: 2 x M16 + 1 x M20.	
	HSO	Stainless steel 316L field mount - Cable entry: 2 x M20.	
	HSU	Stainless steel 316L field mount - Cable entry: 3 x $\frac{1}{2}$ "NPT.	
	Pressure	<b>IA</b>	(O)4 - 20mA pressure input.
	Digital output	OA	One active transistor output - requires XX.
		OR	One mechanical relay output - requires PF or PM.
<b>OT</b>		<b>One passive transistor output.</b>	
Power	PD	8 - 24V AC/DC + sensor supply - with XI: 16 - 30V DC.	
	PF	24V AC/DC + sensor supply - requires XX.	
	PM	115 - 230V AC + sensor supply - requires XX.	
	<b>PX</b>	<b>Basic power supply 8 - 30V DC.</b>	
Battery	PB	Additional lithium battery powered (optional) - requires XX and PD or PX.	
	PC	Additional lithium battery powered (optional) - Intrinsically safe - requires XI, and PD or PX.	
Temp.	<b>TP</b>	<b>PT100 temperature input.</b>	
Hazardous	XI	Intrinsically safe, according ATEX and IECEx.	
	XF	Ex d enclosure - 3 keys according ATEX and IECEx.	
	<b>XX</b>	<b>Safe area only, according CE / UKCA.</b>	
Options	ZB	Backlight - requires XX.	
	ZF	Coil input 10mVpp.	
	ZV	PRTD-range -200°C / +800°C.	
	<b>ZX</b>	<b>No options.</b>	

The **bold** marked text contains the standard configuration: F126-P-AP-CX-EG-HC-IA-OT-PX-TP-XX-ZX.

